

COMPUTER INSTRUCTIONS

COMPUTER INSTRUCTIONS

MODEL NUMBER: FX4 / FX4M (LED 6)

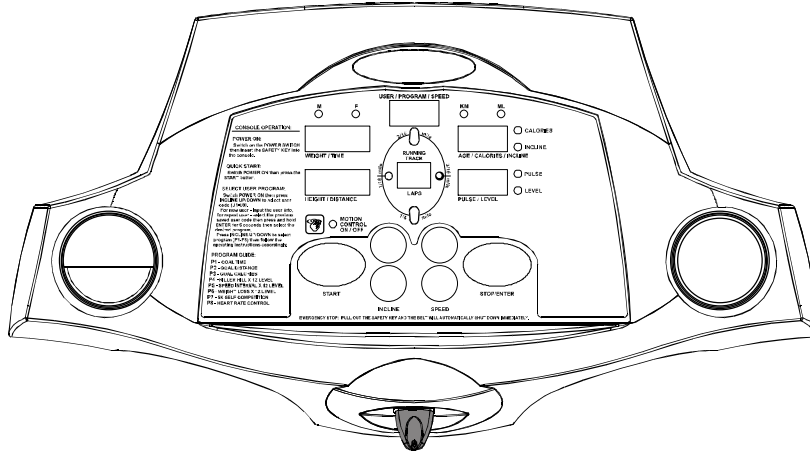

FX4 / FX4M (LED 6) COMPUTER INSTRUCTIONS

COMPUTER OPERATION

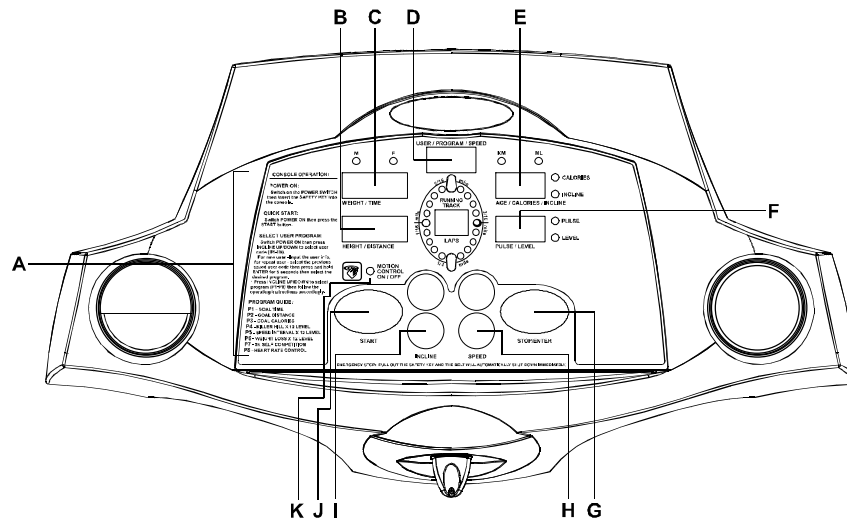

Console Operation	<input type="button" value="A"/>	<input type="button" value="B"/>	Height/Distance
Weight/Time	<input type="button" value="C"/>	<input type="button" value="D"/>	User/Program/Speed
Age/Calories/Incline	<input type="button" value="E"/>	<input type="button" value="F"/>	Pulse/Level
Stop/Enter	<input type="button" value="G"/>	<input type="button" value="H"/>	Speed
Incline	<input type="button" value="I"/>	<input type="button" value="J"/>	Start
Motion Control	<input type="button" value="K"/>	<input type="button" value=""/>	

POWER ON:

Set the POWER SWITCH, located on the bottom of the left handle bar upright tube, to ON and insert the SAFETY KEY. All the LED lights will auto scan then display the factory default setting:

TIME window will display the default user 1 weight: 68KG/150LB
 CALORIES window will display the default user 1 height: 160CM/63"
 SPEED window will display the default user 1 code: U1
 DISTANCE window will display the default user 1 age: 35
 PULSE window will display the default user 1 pulse: 120
 MALE LED will light up as a default setting.
 LAP window will display: 0

If the user 1 information has been changed and saved, then the POWER ON status will show the last saved user 1 information instead of the factory default setting.

SLEEP MODE:

The computer will automatically enter SLEEP MODE if left idle for 3 minutes without any input in POWER ON status. Press any button to return to POWER ON status when the computer is in SLEEP MODE.

COMPUTER OPERATION

3 SECONDS ALERT:

To ensure you are well prepared before the belt starts moving, every time you press the START button to start the belt, the SPEED window will countdown 3 seconds with the LED showing "3-2-1" then the belt will start moving.

PAUSE/STOP:

When the treadmill is running, press the STOP button to pause the treadmill. All figures on the displayed on the LED will freeze. Press START to resume the program and all displays will continue the performance until the program finishes. If you continue pressing the STOP twice, then all data will return to 0 and the treadmill will return to POWER ON status. If there is no action within 30 seconds, the treadmill will return to POWER ON status.

ENGLISH/METRIC CONVERSION:

The treadmill computer display can show ENGLISH and METRIC information. The factory should have the proper setting on this for different markets. In case that the treadmill needs to be converted between METRIC and ENGLISH readout, please follow the procedure as below:

1. Set the POWER SWITCH to ON. Press the START button on the computer and hold it. Insert the SAFETY KEY then release the SPEED DOWN button. The computer will sound one short beep and METRIC LED light up.
2. Press the START button to switch between METRIC/ENGLISH and press the STOP/ENTER button to confirm the selection and return to the POWER ON status.

QUICK START:

When the treadmill is in POWER ON status, press the START button to activate the QUICK START program. The speed will start from 0.5MPH/0.8KMPH. Press the SPEED UP/DOWN button to change the speed. Press the INCLINE switch to elevate the treadmill. The TIME, CALORIES and DISTANCE will count up from 0.

PROGRAM:

To select other programs, you will need to select the USER first. Press the INCLINE UP/DOWN button to select the USER CODE from U1 to U9 then press the STOP/ENTER button to confirm the user code. If the user information has been previously input, press the STOP/ENTER button again and hold it for 5 seconds then the computer will skip the user information set up procedure and enter the program select procedure. To input the new user information, please follow the procedure as below:

SEX set up – After selecting the USER CODE, the MALE LED will light up and begin blinking. Press the INCLINE UP/DOWN button to switch between MALE and FEMALE then press the STOP/ENTER button to confirm.

HEIGHT set up – After the SEX set up procedure, the CALORIES display will show the default or previous setting and begin blinking. Press the INCLINE UP/DOWN button to adjust the user height information then press STOP/ENTER to confirm.

WEIGHT set up – After the HEIGHT set up procedure, the TIME display will show the default or previous setting and begin blinking. Press the INCLINE UP/DOWN button to adjust the user weight information then press STOP/ENTER to confirm.

PROGRAM SELECT:

After completing the user information set up, the PROGRAM LED will show a blinking P1. The program code list is as follows:

- P.1 – GOAL COURSE TIME
- P.2 – GOAL COURSE DISTANCE
- P.3 – GOAL COURSE CALORIES
- P.4 – KILLER HILLS X 12 LEVELS
- P.5 – SPEED INTERVAL X 12 LEVELS
- P.6 – WEIGHT LOST X 12 LEVELS
- P.7 – 5K TRAINING/SELF LEARNING
- P.8 – HEART RATE CONTROL

COMPUTER OPERATION**P.1 GOAL COURSE TIME:**

When the treadmill is in PROGRAM SELECT status, press the INCLINE UP/DOWN button until the program displays P1 then press STOP/ENTER button. The TIME display will show a blinking "00:00". Press the INCLINE UP/DOWN button to set your ideal workout time then press the STOP/ENTER button to confirm the set up and press START to start. The TIME display will count down from the pre-set time and other displays will count up until the treadmill stops. The treadmill will start from 2.0MPH/3.2KMPH. Press the SPEED UP/DOWN button to change the speed. Press the INCLINE UP/DOWN button to elevate the treadmill.

P.2 GOAL COURSE DISTANCE:

When the treadmill is in PROGRAM SELECT status, press the INCLINE UP/DOWN button until the program displays P2 then press STOP/ENTER button. The DISTANCE display will show a blinking "00.0". Press the INCLINE UP/DOWN button to set your ideal workout distance then press the STOP/ENTER button to confirm the set up and press START to start. The DISTANCE display will count down from the pre-set distance and the other displays will count up until the treadmill stops. The treadmill will start from 2.0MPH/3.2KMPH. Press the SPEED UP/DOWN button to change the speed. Press the INCLINE UP/DOWN button to elevate the treadmill.

P.3 GOAL COURSE CALORIES:

When the treadmill is in the PROGRAM SELECT status, press the INCLINE UP/DOWN button until the program displays P3 then press the STOP/ENTER button. The CALORIES display will show a blinking "0.0", press the INCLINE UP/DOWN button to set your ideal workout calories then press STOP/ENTER button to confirm the set up and press START to start. The CALORIES display will count down from the pre-set calories and the other display will count up until the treadmill stops. The treadmill will start from 2.0MPH/3.2KMPH. Press the SPEED UP/DOWN button to change the speed. Press the INCLINE UP/DOWN button to elevate the treadmill.

P.4 KILLER HILLS:

When the treadmill is in PROGRAM SELECT status, press the INCLINE UP/DOWN button until the program displays P4 then press STOP/ENTER button. The CALORIES/LEVEL display will show L01 and be blinking. There are total of 12 different workout levels that can be selected. Press the INCLINE UP/DOWN button to select the level then press the STOP/ENTER button. The TIME LED will show a pre-set workout time of 24 minutes. Press the INCLINE UP/DOWN button to adjust the time, 4 minutes per segment for every adjustment. Press the STOP/ENTER button to confirm the workout time then press the START button to start the program. The program will start with 2 minutes in MIN. GRADE% and 2 minutes in MAX. GRADE%. Repeat in 4 minute segments until the time counts down to zero.

Pre-set speed 2.0MPH/3.2KMPH, adjust the speed using the SPEED UP/DOWN BUTTON,

KILLER HILLS WORKOUT

LEVEL	MIN. GRADE%	MAX. GRADE%
1	0	4
2	1	5
3	2	6
4	3	7
5	4	8
6	5	9
7	6	10
8	7	11
9	8	12
10	9	13
11	10	14
12	11	15

COMPUTER OPERATION**P.5 SPEED INTERVAL:**

When treadmill is in PROGRAM SELECT status, press INCLINE UP/DOWN button till program display P5 then press STOP/ENTER button. The CALORIES/LEVEL display will show a blinking L01. There are a total of 12 different workout levels that can be selected. Press the INCLINE UP/DOWN button to select the level then press the STOP/ENTER button. The TIME LED will show a pre-set workout time of 24 minutes. Press the INCLINE UP/DOWN button to adjust the time, 4 minutes per segment for every adjustment. Press the STOP/ENTER button to confirm the workout time then press the START button to start the program. The program will start with 2 minutes in MIN. SPEED and 2 minutes in MAX. SPEED. Repeat this in 4 minutes segments until the time counts down to zero.

Pre-set INCLINE LEVEL at 0%. Adjust the incline level using the INCLINE UP/DOWN button during the workout.

SPEED INTERVAL WORKOUT

LEVEL	MIN. SPEED	MAX. SPEED
1	1.8	3.0
2	2.0	3.4
3	2.2	3.8
4	2.4	4.2
5	2.6	4.6
6	2.8	5.0
7	3.0	5.4
8	3.2	5.8
9	3.4	6.2
10	3.6	6.6
11	3.8	7.0
12	4.0	7.2

P.6 WEIGHT LOST:

When the treadmill is in PROGRAM SELECT status, press the INCLINE UP/DOWN button until the program displays P6 then press the STOP/ENTER button. The CALORIES/LEVEL will display a blinking L01. There are a total of 12 different workout levels that can be selected. Press the INCLINE UP/DOWN button to select the level then press the STOP/ENTER button. The TIME LED will show a pre-set workout time of 30 minutes. Press the INCLINE UP/DOWN button to adjust the time, 5 minutes per segment for every adjustment. Press the STOP/ENTER button to confirm the workout time then press the START button to start the program. The program will start with 2 minutes in MIN. SPEED/GRADE% and 3 minutes in MAX. SPEED/GRADE%. Repeat in 5 minute segments until the time counts down to zero.

WEIGHT LOST WORKOUT

LEVEL	MIN. SPEED	MAX. SPEED	MINI. GRADE%	MAX GRADE%
1	1.6	2.8	0	3
2	1.8	3.0	0	4
3	2.0	3.2	1	5
4	2.2	3.4	1	6
5	2.4	3.6	2	7
6	2.6	3.8	2	8
7	2.8	4.0	3	9
8	3.0	4.2	3	10
9	3.2	4.4	3	11
10	3.4	4.6	4	12
11	3.6	4.8	4	13
12	3.8	5.0	4	14

COMPUTER OPERATION**P.7 5K SELF LEARNING/COMPETITION:**

When the treadmill is in PROGRAM SELECT status, press the INCLINE UP/DOWN button until the program displays a P7 then press the STOP/ENTER button. The DISTANCE LED will show 5(KM)/3(MILE). For new users, there is a pre-set speed and incline% program in the computer. Press the START button to start the program. The user can change the speed and incline level during the workout. The DISTANCE will count down to zero then stop. The result time and calories will be saved and shown on the display so the user can select this program again and to challenge himself using the same program.

P.8 HEART RATE CONTROL:

When the treadmill is in PROGRAM SELECT status, press the INCLINE UP/DOWN button until the program displays P8 then press the STOP/ENTER button to select the program.

AGE SET UP – After selecting the HEART RATE CONTROL program, the AGE LED will begin blinking and show a pre-set age of 35 for the new user or show the previous set age for the repeat user who selected the same user code. Press the INCLINE UP/DOWN button to adjust the user age, the PULSE LED will show the maximum target workout heart rate along with the new age. Press the STOP/ENTER button to confirm the age then press the INCLINE UP/DOWN button to adjust the maximum target workout heart rate. This should be subject to your own body condition or determined after consulting with your doctor then press the STOP/ENTER button to confirm.

TIME SET UP – After completing the AGE set up, the TIME LED will show a blinking pre-set workout time of 60:00. Press the INCLINE UP/DOWN button to adjust the workout time then press the STOP/ENTER button to confirm. Press the START button to start the program. During the program please make sure to hold the hand pulse contact sensor on the handle bar at all times. Failure to hold the contact sensor will cause the program fail and discontinue.

WARM UP – After completing the TIME set up and starting the program, there is a 3 minute WARM UP program to help you reach the minimum target workout heart rate. The speed will start from 2MILE/3.2KM and the incline level will start from 0. If the actual pulse rate does not reach the minimum target workout heart rate, the speed will increase 0.5MILE/0.8KM every 15 seconds. When the actual pulse rate reaches the minimum target workout heart rate, the speed will stop increasing and continue the same speed until the 3 minute warm up is complete and then go into the HEART RATE CONTROL main program. If you cannot reach the minimum target workout heart rate in 3 minutes, the program will continue the 2nd 3 minute WARM UP program. During the 2nd WARM UP program, the speed will remain the same speed as in the first WARM UP program. If the actual pulse rate cannot reach the minimum target workout heart rate, the incline level will add 1% every 15 seconds. When the actual pulse rate reaches the minimum target workout heart rate, the incline will stop changing and continue the same speed and same incline level until the time counts down to zero then enters the HEART RATE CONTROL main program. If during the 2nd WARM UP the user still can not reach the minimum target workout heart rate, the computer will continue on to the 3rd WARM UP procedure for 3 minutes and both speed and incline level will be remain the same as the 2nd WARM UP until the time counts down to zero. If the 3rd WARM UP program still cannot bring up the actual pulse rate to the minimum target workout heart rate, the program will stop and SPEED LED will show FAIL.

HEART RATE CONTROL MAIN PROGRAM – After the actual pulse rate reaches the minimum target workout heart rate and completes the warm up program, the computer will go into the main program and the time will count down from the pre-set time. During the main program, if the actual pulse rate cannot reach the maximum target workout heart rate, the incline level will be increased by 1% every 15 seconds until the pulse rate reaches the maximum target workout heart rate or the incline level will increase by 15%. After the incline level increases to 15% but still does not reach the maximum target workout heart rate the speed will be increase by 0.5MILE/0.8KM every 15 seconds until the pulse rate reaches the maximum target workout heart rate. If the actual pulse is higher than the maximum target workout heart rate, then the incline will be reduced 1% every 15 seconds until the actual heart rate meets the maximum target workout heart rate or the incline level will lower to 0%. Then the speed will be reduced by 0.5MILE/0.8KM every 15 seconds until the actual pulse meets the maximum target workout heart rate.

COOL DOWN – After completing the HEART RATE CONTROL program and the time counts down to zero start the one minute cool down program. The incline will return to 0% and the speed will lower to 2MILE/3.2KM as the time counts down from 1:00.

COMPUTER OPERATION**USING THE CHEST BELT HEART RATE MONITOR:**

For proper operation, the chest belt should be worn with the monitor strapped across the front of your body just above the chest line as shown in the drawing on the right. The monitor needs a little body heat and moisture in order to work properly. To ensure correct operation you may want to wet the two rubber pickups under the belt prior to exercising.

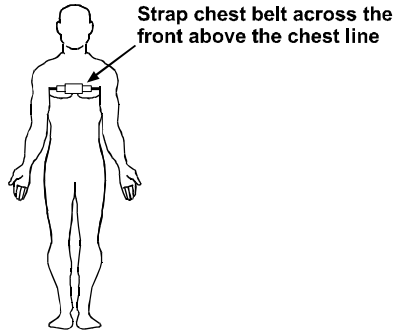

MOTION CONTROL OPERATION (FX4M Only)**MOTION CONTROL:**

1. Press the  button on the console to switch the motion control function on and off:

?? When the LED light is **ON** the MOTION CONTROL is **active**.
 ?? When the LED light is **OFF** the MOTION CONTROL is **off**.

2. After switching on the MOTION CONTROL wave your right hand approximately 6 inches above the motion sensor on the right handle bar to increase the speed. The sensor will sound one short BEEP per scan and speed up by 0.1 MPH per BEEP. Holding your right hand approximately 6 inches above the right sensor constantly results in the sensor sounding one long BEEP per second and speeding up by 0.5 MPH per BEEP.



2. Use right sensor to speed up.

3. Wave you left hand approximately 6 inches above the motion sensor on the left handle bar to decrease the speed. The sensor will sound one short BEEP per scan and decrease speed by 0.1 MPH. Holding your left hand approximately 6 inches above the left sensor constantly results in the sensor sounding one long BEEP per second and decreasing speed by 0.5 MPH per BEEP.



3. Use left sensor to slow down.

4. Wave both hands approximately 6 inches above both motion sensors at the same time. The sensor will sound two short BEEPs then stop the belt.

?? **Always switch off the MOTION CONTROL function by pressing the  button before turning off the power to the treadmill.**



4. Use both sensors to stop belt.

